

# SERVICE INSTRUCTION

DATE: May 26, 2009

Service Instruction No. 1324C  
(Supersedes Service Instruction No. 1324B)Engineering Aspects are  
FAA Approved

SUBJECT: Crankshaft Oil Seals

MODELS AFFECTED: All direct drive series engines.

TIME OF COMPLIANCE: At anytime the front crankshaft oil seal is replaced.

The two crankcase front bearing oil seals used in Lycoming direct drive engines are the split seal and the solid ring stretch seal. The split seal is open to permit assembly around the crankshaft. The solid seal is made from a highly elastic material that allows the seal to be stretched over the crankshaft propeller flange during assembly.

To minimize oil leaks that occur in the area of the front crankshaft oil seal and prevent the seal from rotating in the crankcase bore, a thorough cleaning of the crankcase bore and use of the correct sealant is necessary. The crankcase must be cleaned of all traces of the oil sealant and oil before a new seal is installed. Use one of the following solvents: methyl ethyl ketone, acetone, Napasco SC-200, M-17 or M-114.

To repair the crankcase in which the oil seal bore is worn oversized, complete disassembly of engine is necessary. A .050 inch oversize split seal (P/N 78443-P50) and .050 inch oversize solid seal (P/N LW-15628-P50) have been provided for engines with **large** bore crankcases. A .050 inch oversize split seal (LW-11997-P50) and .050 inch oversize solid seal (LW-13792-P50) have been provided for engines with **small** bore crankcases. Both solid and split seals are available in standard size as well as oversize.

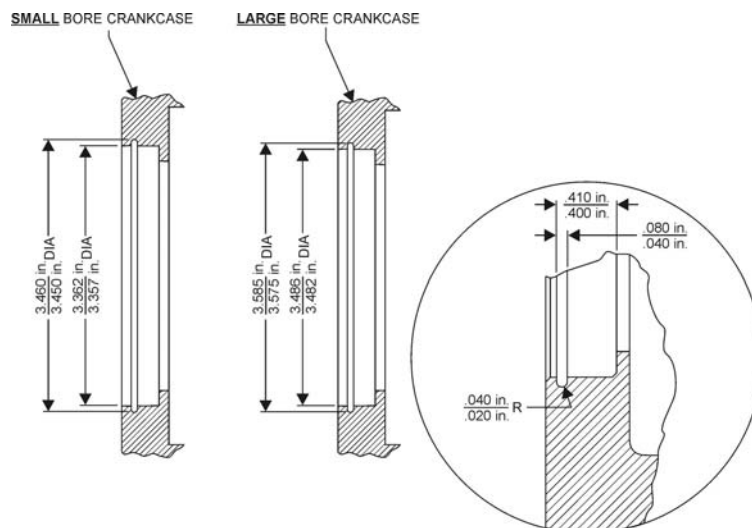

Figure 1. Crankcase Bore Dimension for Oversize Crankshaft Seal

General Aviation  
Manufacturers Association

ISSUED			REVISED			PAGE NO.	REVISION
MO	DAY	YEAR	MO	DAY	YEAR	1 of 4	C
02	27	76	05	26	09		

©2009 by Lycoming "All Rights Reserved"

Lycoming Engines, a division of AVCO Corporation, a wholly owned subsidiary of Textron Inc.

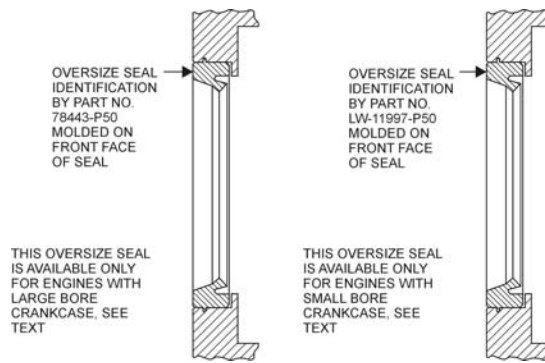

Figure 2. Identification of Oversize Crankshaft Seal

To accommodate the oversize seal, it is necessary to increase the crankcase nose seal bore on both large and small bore crankcases. Increase the diameter on large bore crankcases to 3.482/3.486 inch, and on small bore crankcases to 3.357/3.362 inch. This can be accomplished on any suitable boring machine. Both the large bore crankcase diameter (3.482/3.486 inch) and the small bore crankcase diameter (3.357/3.362 inch) must be concentric with the oversize bearing diameter to within 0.005 inch Total Indicator Reading (T.I.R.).

The .050 inch oversize nose seals are identified by the P/N's 78443-P50 or LW-11997-P50 molded on the face of the seals as shown in Figure 2. Except for the revised outside diameter of the seals, they are identical in other aspects to the standard seals, P/N 78443 and P/N LW-11997.

The installation of the split nose seals P/N 76940, 78443, 78443-P50, LW-11997 or LW-11997-P50 is as follows:

1. Assemble the split seal on the crankshaft with the front face of the seal (as identified in Figure 2) toward the crankshaft propeller flange.
2. Using an appropriate solvent, remove the grease from the crankshaft flange; the outer surface of the seal and from the crankcase seal bore recess. Apply a thin coat of adhesive (Dow Corning 737 Neutral Cure Sealant\*) to the inner bore of the crankcase seal bore recess. Apply a thin coat of adhesive (Dow Corning 737 Neutral Cure Sealant\*) to the outside diameter and the split of the seal. Do not allow any adhesive to come into contact with the crankshaft and especially the oil return port. If any adhesive comes into contact with the crankshaft or oil return port, use acetone to remove all traces of it.
3. Face the propeller end of the crankshaft and assemble the seal with the split at 1:00 o'clock on standard rotation engines and at 11:00 o'clock on reverse rotation engines. Apply a fresh coat of adhesive (Dow Corning 737 Neutral Cure Sealant\*) to the inside diameter of the crankcase then press the seal firmly against the seat in the crankcase bore.
4. Allow 24 hours for the Dow 737 Neutral Cure Sealant to cure.\*\*
5. Reattach the starter ring gear support and the propeller.

The installation for the solid ring nose seals P/N LW-13792, LW-13792-P50, LW-15628 and LW-15628-P50 is as follows:

1. Remove propeller and starter ring gear support from the crankshaft propeller flange.
2. Remove the front crankshaft oil seal from the crankcase and clean the recess with a cloth and one of the following solvents; methyl ethyl ketone, acetone, Napasco SC-200, M-17 or M-114.

\* If Dow Corning 737 Neutral Cure Sealant is not available, Pliobond #20 may be used.

\*\* If substituting the Dow sealant with Pliobond #20, allow 15 minutes for the Pliobond #20 to cure.

ISSUED			REVISED			PAGE NO.	REVISION	S.I. 1324
MO	DAY	YEAR	MO	DAY	YEAR	2 of 4	C	
02	27	76	05	26	09			

3. Inspect the propeller flange, crankshaft sealing surface and the crankcase seal bore recess for any scratches or nicks that damage or cause the seal to leak; if found, remove with fine emery cloth (150 to 220 grit for very light metal sanding) or equivalent small fine abrasive stone.
4. Remove the spring from the inside of a new seal and unhook spring.

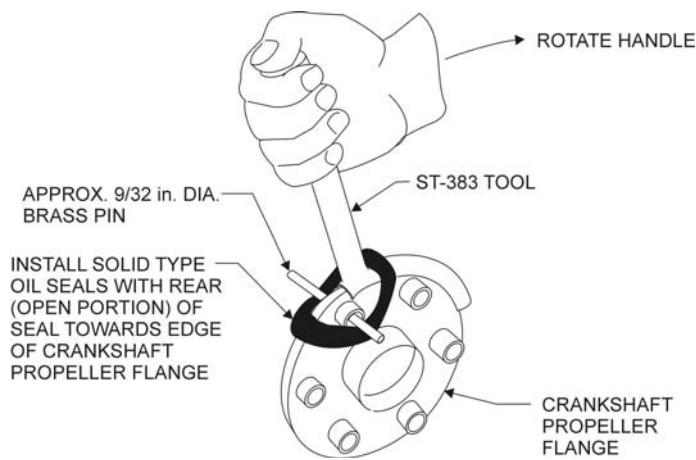

Figure 3. Crankshaft Propeller Flange Showing Installation of Stretch Seal



Figure 4. Crankshaft Propeller Flange Showing Installation of Stretch Seal Using a Guard Over the Front of the Flange

5. Apply a thin film of Lubriko M-6 grease on the sealing surface of the seal; around the crankshaft at the sealing surface; and on the outer edge of the crankshaft flange.

NOTE

If the crankshaft is not reinstalled in an engine, secure it in a vise or other suitable support to prevent it from moving during assembly of the stretch seal.

6. Place seal over edge of crankshaft propeller flange with rear (open portion) of seal toward the flange. See Figure 3.
7. Slip a brass pin approximately 9/32 inch diameter x 3 inch long through crankshaft propeller flange bushing to retain both sides of stretch seal. (See Figure 3.)
8. Install tool ST-383 under seal and over edge of crankshaft propeller flange as shown in Figures 3 and 4, and with even pressure on the hand, force the seal over the crankshaft propeller flange. Check to be certain no damage occurred to the seal while it was being installed over the flange.

NOTE

A pinion cage oil retaining housing P/N 68293 or P/N LW-11174 may be used as a guard over the front of the crankshaft flange to minimize interference from the flange bushings and the hub pilot while the seal is being installed. The use of the guard is shown in Figure 4.

9. Place the seal spring around the crankshaft, join the two ends together and hook. The spring must form a continuous circle around the crankshaft with no kinks or twists.
10. Work the spring into position in the groove (open portion) provided in the rear side of the seal.

ISSUED			REVISED			PAGE NO.	REVISION	S.I. 1324
MO	DAY	YEAR	MO	DAY	YEAR			
02	27	76	05	26	09	3 of 4	C	

11. Using an appropriate solvent, remove the grease film from the crankshaft flange; the outer surface of the seal and from the crankcase seal bore recess. Apply a thin coat of adhesive ( Dow Corning 737 Neutral Cure Sealant\*) to the outside diameter of the nose seal and to the inner bore of the crankcase seal bore recess. Do not allow any adhesive to come into contact with the crankshaft and especially the oil return port. If any adhesive comes into contact with the crankshaft or oil return port, use acetone to remove all traces of it.
12. Insert the seal in crankcase bore. Apply pressure all around the nose seal until it is seated firmly in the bore.
13. Allow 24 hours for the Dow 737 to cure.\*\*
14. Reattach the starter ring gear support and the propeller

PARTS DATA:

LW-13792 (Small)	Crankshaft Oil Seal (molded lip on outside surface – solid type – three grooves for glue retention)
LW-13792-P50 (Small)	Crankshaft Oil Seal (.050 oversize Outside Diameter (o/s O.D.) for small bore crankcases – solid type – three grooves for glue retention)
LW-11997 (Small)	Crankshaft Oil Seal (molded lip on outside surface – split type)
LW-11997-P50 (Small)	Crankshaft Oil Seal (.050 o/s O.D. for small bore crankcases – split type)
78443 (Large)	Crankshaft Oil Seal (molded lip on outside surface – split type)
78443-P50 (Large)	Crankshaft Oil Seal (.050 o/s O.D. for large bore crankcases – split type)
LW-15628 (Large)	Crankshaft Oil Seal (molded lip on outside surface – solid type – three grooves for glue retention)
LW-15628-P50 (Large)	Crankshaft Oil Seal (.050 o/s O.D. for large bore crankcases – solid type – three grooves for glue retention)
76940 (Small)	Crankshaft Oil Seal (no molded lip on outside surface – split type)
74305	Crankshaft Oil Seal (two grooves for glue retention – split type)
ST-383	Oil Seal Installation Tool
68293 or LW-11174	Oil Retaining Housing (may be used to aid in installing seal)

\* If Dow Corning 737 Neutral Cure Sealant is not available, Pliobond #20 may be used.

\*\* If substituting the Dow sealant with Pliobond #20, allow 15 minutes for the Pliobond #20 to cure.

ISSUED			REVISED			PAGE NO.	REVISION	S.I. 1324
MO	DAY	YEAR	MO	DAY	YEAR			
02	27	76	05	26	09	4 of 4	C	